

Ruční kolečka rýhovaná

Technopolymer

MATERIÁL

Technopolymer na bázi polyamidu (PA), barva černá, matný povrch.

STANDARDNÍ PŘEVODNÍ

- **BT-B**: pouzdro z mosazi, slepý závitový otvor.
- **BT-SST**: pouzdro z nerezové oceli AISI 303, slepý závitový otvor.
- **BT-FP**: pouzdro z mosazi, průchozí závitový otvor.
- **BT-SST-FP**: pouzdro z nerezové oceli AISI 303, průchozí závitový otvor.
- **BT-p**: závitový čep z pozinkované oceli se zkoseným plochým koncem podle UNI 947 : ISO 4753 (informace v kapitole Technická data viz. strana).
- **BT-SST-p**: závitový čep z nerezové oceli AISI 303 se zkoseným plochým koncem podle UNI 947 : ISO 4753 (informace v kapitole Technická data viz. strana).



ELESA Original design

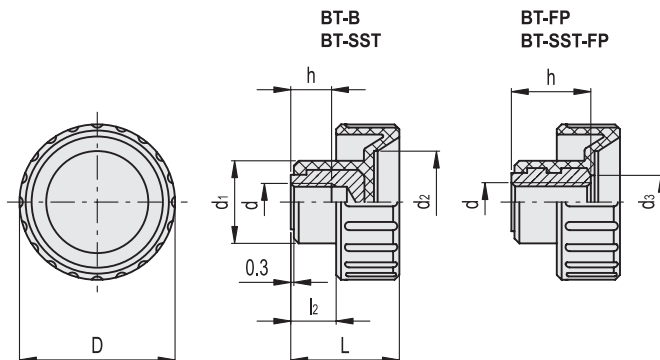

BT-B

Kód	Označení	D	d6H	L	d1	d2	l2	h	⚖
6310	BT.12 B-M3	12	M3	11.5	9.5	6	4	6	5
6311	BT.12 B-M4	12	M4	11.5	9.5	6	4	6	4
6312	BT.12 B-M5	12	M5	11.5	9.5	6	4	6	3
6320	BT.16 B-M3	16	M3	13	11	9	5	6	6
6321	BT.16 B-M4	16	M4	13	11	9	5	6	5
6322	BT.16 B-M5	16	M5	13	11	9	5	6	4
6323	BT.16 B-M6	16	M6	13	11	9	5	6	3
6521	BT.20 B-M5	20	M5	15	11.5	11	6	6	6
6522	BT.20 B-M6	20	M6	15	11.5	11	6	6	7
6611	BT.25 B-M5	26	M5	19	16	15	8	6	10
6621	BT.25 B-M6	26	M6	19	16	15	8	8	9
6720	BT.32 B-M6	32	M6	22	17	21	9	10	13
6721	BT.32 B-M8	32	M8	22	17	21	9	10	11
6811	BT.40 B-M8	40	M8	27	19	25	13	13	21
6813	BT.40 B-M10	40	M10	27	19	25	13	13	19
6863	BT.50 B-M10	50	M10	28.5	22	31	13.5	13	25

BT-FP

Kód	Označení	D	d6H	L	d1	d2	d4	l2	h	⚖
6331	BT.16 FP-M4	16	M4	13	11	9	5	5	10	4
6336	BT.16 FP-M5	16	M5	13	11	9	6	5	10	5
6530	BT.20 FP-M5	20	M5	15	11.5	11	6	6	12	8
6531	BT.20 FP-M6	20	M6	15	11.5	11	7	6	12	7
6631	BT.25 FP-M6	26	M6	19	16	15	7	8	14	9
6636	BT.25 FP-M8	26	M8	19	16	15	9	8	14	11
6730	BT.32 FP-M6	32	M6	22	17	21	7	9	16	18
6731	BT.32 FP-M8	32	M8	22	17	21	10	9	16	15
6732	BT.32 FP-M10	32	M10	22	17	21	11	9	16	13
6803	BT.40 FP-M10	40	M10	27	19	25	14	13	20	25
6850	BT.50 FP-M10	50	M10	28.5	22	31	14	13.5	20	32

BT-SST

STAINLESS STEEL

Kód	Označení	D	d6H	L	d1	d2	l2	h	⚖
106321	BT.16-SST-M4	16	M4	13	11	9	5	6	5
106521	BT.20-SST-M5	20	M5	15	11.5	11	6	6	6
106621	BT.25-SST-M6	26	M6	19	16	15	8	8	9
106721	BT.32-SST-M8	32	M8	22	17	21	9	10	12

BT-SST-FP

STAINLESS STEEL

Kód	Označení	D	d6H	L	d1	d2	d4	l2	h	⚖
106530	BT.20-SST-FP-M5	20	M5	15	11.5	11	6	6	12	7
106631	BT.25-SST-FP-M6	26	M6	19	16	15	7	8	14	9
106731	BT.32-SST-FP-M8	32	M8	22	17	21	10	9	16	15

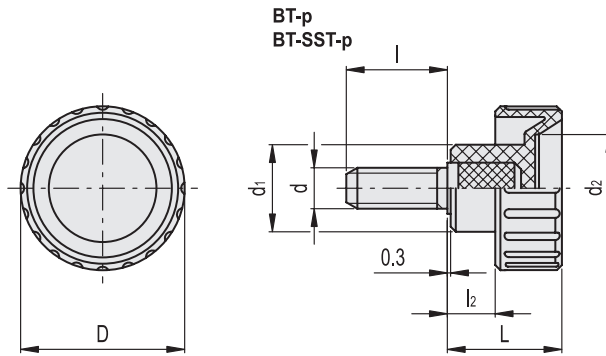

BT-p

Kód	Označení	D	d _{6g}	L	d ₁	d ₂	l	l ₂	⚖
6301	BT.12 p-M2x6	12	M2	11.5	9.5	6	6	4	1
6303	BT.12 p-M2x14	12	M2	11.5	9.5	6	14	4	2
6305	BT.12 p-M2,5x6	12	M2.5	11.5	9.5	6	6	4	1
6307	BT.12 p-M2,5x14	12	M2.5	11.5	9.5	6	14	4	2
6337	BT.12 p-M3x6	12	M3	11.5	9.5	6	6	4	2
6338	BT.12 p-M3x10	12	M3	11.5	9.5	6	10	4	2
6339	BT.12 p-M3x16	12	M3	11.5	9.5	6	16	4	3
6340	BT.12 p-M4x6	12	M4	11.5	9.5	6	6	4	2
6341	BT.12 p-M4x10	12	M4	11.5	9.5	6	10	4	3
6342	BT.12 p-M4x16	12	M4	11.5	9.5	6	16	4	3
6343	BT.12 p-M5x10	12	M5	11.5	9.5	6	10	4	4
6344	BT.12 p-M5x16	12	M5	11.5	9.5	6	16	4	4
6347	BT.16 p-M3x6	16	M3	13	11	9	6	5	2
6348	BT.16 p-M3x10	16	M3	13	11	9	10	5	2
6349	BT.16 p-M3x16	16	M3	13	11	9	16	5	3
6350	BT.16 p-M4x6	16	M4	13	11	9	6	5	2
6351	BT.16 p-M4x10	16	M4	13	11	9	10	5	3
6356	BT.16 p-M4x16	16	M4	13	11	9	16	5	3
6361	BT.16 p-M4x20	16	M4	13	11	9	20	5	4
6366	BT.16 p-M4x30	16	M4	13	11	9	30	5	5
6371	BT.16 p-M5x10	16	M5	13	11	9	10	5	6
6376	BT.16 p-M5x16	16	M5	13	11	9	16	5	7
6541	BT.20 p-M5x10	20	M5	15	11.5	11	10	6	7
6546	BT.20 p-M5x16	20	M5	15	11.5	11	16	6	8
6548	BT.20 p-M5x20	20	M5	15	11.5	11	20	6	8
6551	BT.20 p-M5x25	20	M5	15	11.5	11	25	6	9
6571	BT.20 p-M6x10	20	M6	15	11.5	11	10	6	9
6576	BT.20 p-M6x16	20	M6	15	11.5	11	16	6	11
6581	BT.20 p-M6x25	20	M6	15	11.5	11	25	6	13
6591	BT.20 p-M6x40	20	M6	15	11.5	11	40	6	16
6638	BT.25 p-M6x10	26	M6	19	16	15	10	8	18
6641	BT.25 p-M6x16	26	M6	19	16	15	16	8	20
6643	BT.25 p-M6x20	26	M6	19	16	15	20	8	23
6646	BT.25 p-M6x25	26	M6	19	16	15	25	8	27
6647	BT.25 p-M6x30	26	M6	19	16	15	30	8	30
6649	BT.25 p-M6x50	26	M6	19	16	15	50	8	32
6661	BT.25 p-M8x16	26	M8	19	16	15	16	8	22
6666	BT.25 p-M8x25	26	M8	19	16	15	25	8	27
6743	BT.32 p-M6x16	32	M6	22	17	21	16	9	23
6744	BT.32 p-M6x20	32	M6	22	17	21	20	9	25
6746	BT.32 p-M6x30	32	M6	22	17	21	30	9	27
6753	BT.32 p-M8x16	32	M8	22	17	21	16	9	25
6754	BT.32 p-M8x20	32	M8	22	17	21	20	9	28
6755	BT.32 p-M8x25	32	M8	22	17	21	25	9	31
6756	BT.32 p-M8x30	32	M8	22	17	21	30	9	35
6758	BT.32 p-M8x40	32	M8	22	17	21	40	9	42
6763	BT.32 p-M10x20	32	M10	22	17	21	20	9	32
6764	BT.32 p-M10x25	32	M10	22	17	21	25	9	34
6765	BT.32 p-M10x30	32	M10	22	17	21	30	9	37
6768	BT.32 p-M10x40	32	M10	22	17	21	40	9	42
6833	BT.40 p-M10x30	40	M10	27	19	25	30	13	40
6883	BT.50 p-M10x30	50	M10	28.5	22	31	30	13.5	44



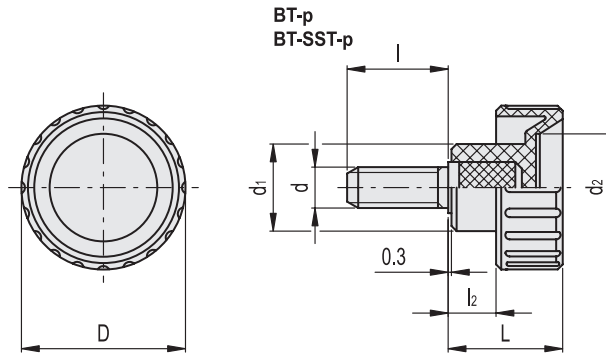

BT-SST-p

STAINLESS STEEL

Kód	Označení	D	d6g	L	d1	d2	l	l2	△△
106337	BT.12-SST-p-M3x6	12	M3	11.5	9.5	6	6	4	2
106338	BT.12-SST-p-M3x10	12	M3	11.5	9.5	6	10	4	2
106339	BT.12-SST-p-M3x16	12	M3	11.5	9.5	6	16	4	3
106350	BT.16-SST-p-M4x6	16	M4	13	11	9	6	5	2
106351	BT.16-SST-p-M4x10	16	M4	13	11	9	10	5	3
106356	BT.16-SST-p-M4x16	16	M4	13	11	9	16	5	3
106541	BT.20-SST-p-M5x10	20	M5	15	11.5	11	10	6	8
106542	BT.20-SST-p-M5x16	20	M5	15	11.5	11	16	6	9
106642	BT.25-SST-p-M6x16	26	M6	19	16	15	16	8	20
106644	BT.25-SST-p-M6x20	26	M6	19	16	15	20	8	24
106647	BT.25-SST-p-M6x30	26	M6	19	16	15	30	8	28
106752	BT.32-SST-p-M8x16	32	M8	22	17	21	16	9	26
106754	BT.32-SST-p-M8x20	32	M8	22	17	21	20	9	29
106757	BT.32-SST-p-M8x30	32	M8	22	17	21	30	9	36

Utahovací kolečka 2