

Regulovatelné páky z nerezí

se závitovým pouzdem /
se závitovým čepem, matně pískovaná

SPECIFIKACE

Typy

- Typ **AS**: s vnějším šestihranem
- Typ **IS**: s vnitřním šestihranem

Rukojeť

- Přesný odlitek z nerezové oceli
- AISI CF-8
- matně pískovaná

Provedení s vnitřním závitem

- Pouzdro
- Nerezová ocel AISI 303
- Upevňovací šroub.
- Nerezová ocel AISI 303

- Pružina
- Nerezová ocel AISI 301

Provedení se závitovým čepem

- Závitový čep
- Nerezová ocel AISI 303
- Upevňovací šroub.
- Nerezová ocel AISI 303

- Pružina
- Nerezová ocel AISI 301

INFORMACE

Regulovatelné páky GN 300.5 s celou pákou z nerezové oceli umožňují použití v "agresivních" podmínkách nebo tam, kde jsou materiály z nerezové oceli předepsány, např. v potravinářství a chemickém průmyslu.

Neumožňují usazování nečistot a vody v prohlubních připevňovacích šroubů (jako u šroubů s vnitřním šestihranem).

Regulovatelné páky se používají tam, kde je zapotřebí upnutí ve stísněném prostoru nebo tam, kde je požadována konkrétní poloha páky. Středová vložka je spojena s pákou prostřednictvím ozubení, které lze snadno rozpojit.

Zatažením za páku se rozpojí ozubení a umožní otočení páky do ideální upínací polohy. Po uvolnění páky se ozubení automaticky znovu spojí.

* Doplňte označení o typ páky (AS nebo IS)

AS	IS
Vnější šestihran	Vnitřní šestihran



TECHNICKÉ INFORMACE

- Základní tolerance ISO (viz. strana A21)
- Vlastnosti nerezové oceli (viz. strana A26)

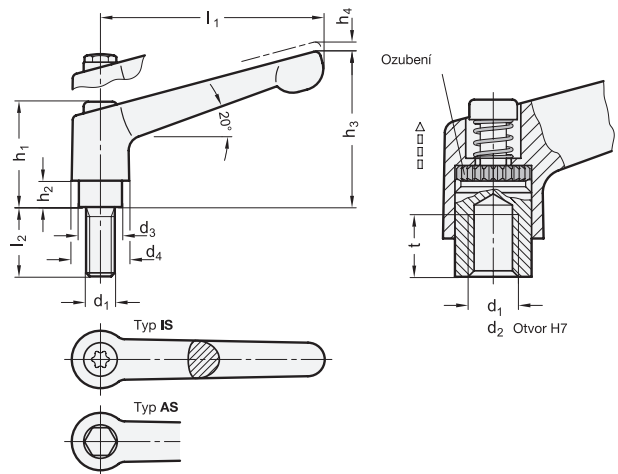

GN 300.5-se závitovým pouzdem

STAINLESS STEEL

Označení	l1	d1	d2 H7	d3	d4	h1	h2	h3	h4	t min.	
GN 300.5-30-B5-*	30	-	B 5	10	13	24.5	4	31	3.5	8	27
GN 300.5-30-B6-*	30	-	B 6	10	13	24.5	4	31	3.5	8	28
GN 300.5-30-M3-*	30	M 3	-	10	13	24.5	4	31	3.5	7	25
GN 300.5-30-M4-*	30	M 4	-	10	13	24.5	4	31	3.5	8	31
GN 300.5-30-M5-*	30	M 5	-	10	13	24.5	4	31	3.5	8	29
GN 300.5-30-M6-*	30	M 6	-	10	13	24.5	4	31	3.5	8	30
GN 300.5-45-B5-*	45	-	B 5	10	13	24.5	4	34	3.5	8	35
GN 300.5-45-B6-*	45	-	B 6	10	13	24.5	4	34	3.5	8	36
GN 300.5-45-M4-*	45	M 4	-	10	13	24.5	4	34	3.5	8	44
GN 300.5-45-M5-*	45	M 5	-	10	13	24.5	4	34	3.5	8	40
GN 300.5-45-M6-*	45	M 6	-	10	13	24.5	4	34	3.5	8	39

GN 300.5-se závitovým pouzdem

STAINLESS STEEL

Označení	l1	d1	d2 H7	d3	d4	h1	h2	h3	h4	t min.	
GN 300.5-63-B8-*	63	-	B 8	13.5	17.5	31	6.5	45	4	11	86
GN 300.5-63-M6-*	63	M 6	-	13.5	17.5	31	6.5	45	4	11	85
GN 300.5-63-M8-*	63	M 8	-	13.5	17.5	31	6.5	45	4	11	84
GN 300.5-78-M8-*	78	-	B 8	16	21	36	8	54	4	14	140
GN 300.5-78-M10-*	78	-	B 10	16	21	36	8	54	4	14	138
GN 300.5-78-M8-*	78	M 8	-	16	21	36	8	54	4	14	137
GN 300.5-78-M10-*	78	M 10	-	16	21	36	8	54	4	14	135
GN 300.5-78-M12-*	78	M 12	-	16	21	36	8	54	4	14	132
GN 300.5-92-M10-*	92	-	B 12	19	24	43	11	64	4	17	220
GN 300.5-92-M10-*	92	M 10	-	19	24	43	11	64	4	17	218
GN 300.5-92-M12-*	92	M 12	-	19	24	43	11	64	4	17	216

Váha pro typ AS

* Doplníte označení o typ páky (AS nebo IS)

AS	IS
Vnější šestihran	Vnitřní šestihran

GN 300.5-se závitovým čepem

STAINLESS STEEL

Označení	l1	d1	l2	d3	d4	h1	h2	h3	h4	Δ
GN 300.5-30-M3-6-*	30	M 3	6	10	13	24.5	4	31	3.5	28
GN 300.5-30-M3-8-*	30	M 3	8	10	13	24.5	4	31	3.5	29
GN 300.5-30-M3-10-*	30	M 3	10	10	13	24.5	4	31	3.5	30
GN 300.5-30-M3-12-*	30	M 3	12	10	13	24.5	4	31	3.5	31
GN 300.5-30-M3-16-*	30	M 3	16	10	13	24.5	4	31	3.5	32
GN 300.5-30-M4-12-*	30	M 4	12	10	13	24.5	4	31	3.5	32
GN 300.5-30-M4-16-*	30	M 4	16	10	13	24.5	4	31	3.5	33
GN 300.5-30-M4-20-*	30	M 4	20	10	13	24.5	4	31	3.5	34
GN 300.5-30-M4-25-*	30	M 4	25	10	13	24.5	4	31	3.5	35
GN 300.5-30-M4-32-*	30	M 4	32	10	13	24.5	4	31	3.5	36
GN 300.5-30-M5-12-*	30	M 5	12	10	13	24.5	4	31	3.5	32
GN 300.5-30-M5-16-*	30	M 5	16	10	13	24.5	4	31	3.5	33
GN 300.5-30-M5-20-*	30	M 5	20	10	13	24.5	4	31	3.5	33
GN 300.5-30-M5-25-*	30	M 5	25	10	13	24.5	4	31	3.5	34
GN 300.5-30-M5-32-*	30	M 5	32	10	13	24.5	4	31	3.5	35
GN 300.5-30-M5-40-*	30	M 5	40	10	13	24.5	4	31	3.5	36
GN 300.5-30-M5-50-*	30	M 5	50	10	13	24.5	4	31	3.5	37
GN 300.5-30-M6-12-*	30	M 6	12	10	13	24.5	4	31	3.5	33
GN 300.5-30-M6-16-*	30	M 6	16	10	13	24.5	4	31	3.5	34
GN 300.5-30-M6-20-*	30	M 6	20	10	13	24.5	4	31	3.5	33.5
GN 300.5-30-M6-25-*	30	M 6	25	10	13	24.5	4	31	3.5	35
GN 300.5-30-M6-32-*	30	M 6	32	10	13	24.5	4	31	3.5	40
GN 300.5-30-M6-40-*	30	M 6	40	10	13	24.5	4	31	3.5	42
GN 300.5-30-M6-50-*	30	M 6	50	10	13	24.5	4	31	3.5	43
GN 300.5-45-M4-12-*	45	M 4	12	10	13	24.5	4	34	3.5	43
GN 300.5-45-M4-16-*	45	M 4	16	10	13	24.5	4	34	3.5	44
GN 300.5-45-M4-20-*	45	M 4	20	10	13	24.5	4	34	3.5	42
GN 300.5-45-M4-25-*	45	M 4	25	10	13	24.5	4	34	3.5	43
GN 300.5-45-M4-32-*	45	M 4	32	10	13	24.5	4	34	3.5	44
GN 300.5-45-M5-12-*	45	M 5	12	10	13	24.5	4	34	3.5	40
GN 300.5-45-M5-16-*	45	M 5	16	10	13	24.5	4	34	3.5	41
GN 300.5-45-M5-20-*	45	M 5	20	10	13	24.5	4	34	3.5	42
GN 300.5-45-M5-25-*	45	M 5	25	10	13	24.5	4	34	3.5	44
GN 300.5-45-M5-32-*	45	M 5	32	10	13	24.5	4	34	3.5	45
GN 300.5-45-M5-40-*	45	M 5	40	10	13	24.5	4	34	3.5	47
GN 300.5-45-M5-50-*	45	M 5	50	10	13	24.5	4	34	3.5	48
GN 300.5-45-M6-12-*	45	M 6	12	10	13	24.5	4	34	3.5	40
GN 300.5-45-M6-16-*	45	M 6	16	10	13	24.5	4	34	3.5	41
GN 300.5-45-M6-20-*	45	M 6	20	10	13	24.5	4	34	3.5	43
GN 300.5-45-M6-25-*	45	M 6	25	10	13	24.5	4	34	3.5	44
GN 300.5-45-M6-32-*	45	M 6	32	10	13	24.5	4	34	3.5	45
GN 300.5-45-M6-40-*	45	M 6	40	10	13	24.5	4	34	3.5	46
GN 300.5-45-M6-50-*	45	M 6	50	10	13	24.5	4	34	3.5	50
GN 300.5-63-M6-16-*	63	M 6	16	13.5	17.5	31	6.5	45	4	73
GN 300.5-63-M6-20-*	63	M 6	20	13.5	17.5	31	6.5	45	4	80
GN 300.5-63-M6-25-*	63	M 6	25	13.5	17.5	31	6.5	45	4	90
GN 300.5-63-M6-32-*	63	M 6	32	13.5	17.5	31	6.5	45	4	100

GN 300.5-se závitovým čepem

STAINLESS STEEL

Označení	l1	d1	l2	d3	d4	h1	h2	h3	h4	Δ
GN 300.5-63-M6-40-*	63	M 6	40	13.5	17.5	31	6.5	45	4	102
GN 300.5-63-M6-50-*	63	M 6	50	13.5	17.5	31	6.5	45	4	105
GN 300.5-63-M6-63-*	63	M 6	63	13.5	17.5	31	6.5	45	4	106
GN 300.5-63-M8-16-*	63	M 8	16	13.5	17.5	31	6.5	45	4	108
GN 300.5-63-M8-20-*	63	M 8	20	13.5	17.5	31	6.5	45	4	109
GN 300.5-63-M8-25-*	63	M 8	25	13.5	17.5	31	6.5	45	4	110
GN 300.5-63-M8-32-*	63	M 8	32	13.5	17.5	31	6.5	45	4	112
GN 300.5-63-M8-40-*	63	M 8	40	13.5	17.5	31	6.5	45	4	114
GN 300.5-63-M8-50-*	63	M 8	50	13.5	17.5	31	6.5	45	4	116
GN 300.5-63-M8-63-*	63	M 8	63	13.5	17.5	31	6.5	45	4	118
GN 300.5-78-M8-20-*	78	M 8	20	16	21	36	8	54	4	130
GN 300.5-78-M8-25-*	78	M 8	25	16	21	36	8	54	4	140
GN 300.5-78-M8-32-*	78	M 8	32	16	21	36	8	54	4	150
GN 300.5-78-M8-40-*	78	M 8	40	16	21	36	8	54	4	155
GN 300.5-78-M8-50-*	78	M 8	50	16	21	36	8	54	4	168
GN 300.5-78-M8-63-*	78	M 8	63	16	21	36	8	54	4	173
GN 300.5-78-M8-80-*	78	M 8	80	16	21	36	8	54	4	176
GN 300.5-78-M10-20-*	78	M 10	20	16	21	36	8	54	4	160
GN 300.5-78-M10-25-*	78	M 10	25	16	21	36	8	54	4	165
GN 300.5-78-M10-32-*	78	M 10	32	16	21	36	8	54	4	170
GN 300.5-78-M10-40-*	78	M 10	40	16	21	36	8	54	4	175
GN 300.5-78-M10-50-*	78	M 10	50	16	21	36	8	54	4	180
GN 300.5-78-M10-63-*	78	M 10	63	16	21	36	8	54	4	182
GN 300.5-78-M10-80-*	78	M 10	80	16	21	36	8	54	4	185
GN 300.5-78-M12-20-*	78	M 12	20	16	21	36	8	54	4	165
GN 300.5-78-M12-25-*	78	M 12	25	16	21	36	8	54	4	168
GN 300.5-78-M12-32-*	78	M 12	32	16	21	36	8	54	4	174
GN 300.5-78-M12-40-*	78	M 12	40	16	21	36	8	54	4	180
GN 300.5-78-M12-50-*	78	M 12	50	16	21	36	8	54	4	189
GN 300.5-78-M12-63-*	78	M 12	63	16	21	36	8	54	4	195
GN 300.5-78-M12-80-*	78	M 12	80	16	21	36	8	54	4	207
GN 300.5-92-M10-20-*	92	M 10	20	19	24	43	11	64	4	214
GN 300.5-92-M10-25-*	92	M 10	25	19	24	43	11	64	4	230
GN 300.5-92-M10-32-*	92	M 10	32	19	24	43	11	64	4	240
GN 300.5-92-M10-40-*	92	M 10	40	19	24	43	11	64	4	260
GN 300.5-92-M10-50-*	92	M 10	50	19	24	43	11	64	4	270
GN 300.5-92-M10-63-*	92	M 10	63	19	24	43	11	64	4	275
GN 300.5-92-M10-80-*	92	M 10	80	19	24	43	11	64	4	248
GN 300.5-92-M12-20-*	92	M 12	20	19	24	43	11	64	4	250
GN 300.5-92-M12-25-*	92	M 12	25	19	24	43	11	64	4	252
GN 300.5-92-M12-32-*	92	M 12	32	19	24	43	11	64	4	250
GN 300.5-92-M12-40-*	92	M 12	40	19	24	43	11	64	4	260
GN 300.5-92-M12-50-*	92	M 12	50	19	24	43	11	64	4	265
GN 300.5-92-M12-63-*	92	M 12	63	19	24	43	11	64	4	270
GN 300.5-92-M12-80-*	92	M 12	80	19	24	43	11	64	4	295

Váha pro typ AS