

Zajišťovací čepy s axiálním zajištěním (západky)

SPECIFIKACE

- Čep
Ocel
- pozinkovaná, modrý pozink
- Západky
Nerezová ocel AISI 304 (plech)
- Rukojeť
Plast (Polyamid PA)
- barva černo-šedá
- teplotní odolnost až do 80 °C
- Tlačítko / Jezdec
Plast
- Tlačítko: barva červená
- teplotní odolnost až do 80 °C
- Pružina
Nerezová ocel AISI 301



INFORMACE

- Zajišťovací čepy s axiálním zajištěním GN 114.2 jsou vhodné pro rychlé upevnění, spojení nebo zajištění na různých upínacích systémech a přípravcích. Používají se jako poziční čepy, které musí být často vyjímány a znovu nasazovány.
- Čtvercový tvar západek z nerezové oceli vytváří lineární kontaktní plochu, která poskytuje zvýšenou axiální pevnost ve stříhu. Obě západky lze zatáhnout stisknutím tlačítka, po jeho uvolnění se západky opět vysunou a čep zajistí.
- Hodnoty zatížení pro namáhání stříhem uvedené v tabulce jsou získané teoreticky a mají pouze informativní charakter. Jedná se o doporučené hodnoty a jejich použití vylučuje jakoukoliv zodpovědnost. Některé z nich zahrnují konkrétní podmínky a vlivy okolního prostředí. Uživatel sám musí určit pro jednotlivé případy, zda výrobek je vhodný pro zamýšlené použití.
- Skupina zajišťovacích čepů (viz. strana 868)

PŘÍSLUŠENSTVÍ

- Kuličkové řetězy GN 111 (viz. strana 904)
- Kuličkové řetězy z nerezí GN 111.5 (viz. strana 905)
- Pojistná lanka z nerezí GN 111.2 (viz. strana 906)
- Pojistná lanka spirálová GN 111.4 (viz. strana 908)

TECHNICKÉ INFORMACE

- Vlastnosti nerezové oceli (viz. strana A26)
- Vlastnosti plastu (viz. strana A2)

Otvor pro závěsný kroužek
(kuličkový řetěz)

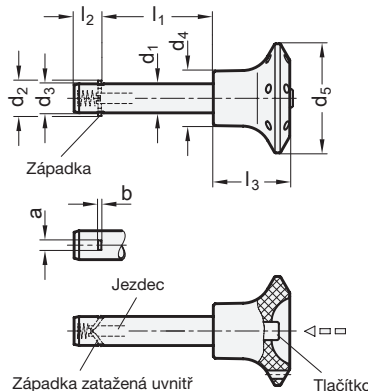
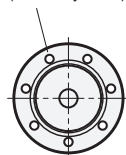

Příklad použití

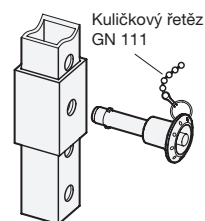

GN 114.2

Označení	d1 -0.1	l1 +0.4	a	b	d2	d3	d4	d5	l2	l3	Zatížení [kN] ≈ (Namáhání ve stříhu) viz. informace	
GN 114.2-6-10	6	10	2.3	0.5	7.5+0.5	5.9	15	30	7	21	14	12
GN 114.2-6-12	6	12	2.3	0.5	7.5+0.5	5.9	15	30	7	21	14	12
GN 114.2-6-16	6	16	2.3	0.5	7.5+0.5	5.9	15	30	7	21	14	12
GN 114.2-6-20	6	20	2.3	0.5	7.5+0.5	5.9	15	30	7	21	14	13
GN 114.2-6-25	6	25	2.3	0.5	7.5+0.5	5.9	15	30	7	21	14	14
GN 114.2-6-30	6	30	2.3	0.5	7.5+0.5	5.9	15	30	7	21	14	15
GN 114.2-6-35	6	35	2.3	0.5	7.5+0.5	5.9	15	30	7	21	14	16
GN 114.2-6-40	6	40	2.3	0.5	7.5+0.5	5.9	15	30	7	21	14	16
GN 114.2-6-45	6	45	2.3	0.5	7.5+0.5	5.9	15	30	7	21	14	17
GN 114.2-6-50	6	50	2.3	0.5	7.5+0.5	5.9	15	30	7	21	14	18
GN 114.2-6-60	6	60	2.3	0.5	7.5+0.5	5.9	15	30	7	21	14	20
GN 114.2-6-70	6	70	2.3	0.5	7.5+0.5	5.9	15	30	7	21	14	22
GN 114.2-6-80	6	80	2.3	0.5	7.5+0.5	5.9	15	30	7	21	14	25
GN 114.2-8-10	8	10	2.8	0.6	10+0.5	7.9	15	30	8.4	21	28	12
GN 114.2-8-16	8	16	2.8	0.6	10+0.5	7.9	15	30	8.4	21	28	16
GN 114.2-8-20	8	20	2.8	0.6	10+0.5	7.9	15	30	8.4	21	28	17
GN 114.2-8-25	8	25	2.8	0.6	10+0.5	7.9	15	30	8.4	21	28	20
GN 114.2-8-30	8	30	2.8	0.6	10+0.5	7.9	15	30	8.4	21	28	21
GN 114.2-8-35	8	35	2.8	0.6	10+0.5	7.9	15	30	8.4	21	28	22
GN 114.2-8-40	8	40	2.8	0.6	10+0.5	7.9	15	30	8.4	21	28	24
GN 114.2-8-45	8	45	2.8	0.6	10+0.5	7.9	15	30	8.4	21	28	26
GN 114.2-8-50	8	50	2.8	0.6	10+0.5	7.9	15	30	8.4	21	28	28
GN 114.2-8-60	8	60	2.8	0.6	10+0.5	7.9	15	30	8.4	21	28	33
GN 114.2-8-70	8	70	2.8	0.6	10+0.5	7.9	15	30	8.4	21	28	36
GN 114.2-8-80	8	80	2.8	0.6	10+0.5	7.9	15	30	8.4	21	28	39
GN 114.2-8-90	8	90	2.8	0.6	10+0.5	7.9	15	30	8.4	21	28	40
GN 114.2-8-100	8	100	2.8	0.6	10+0.5	7.9	15	30	8.4	21	28	46
GN 114.2-10-15	10	15	3.3	1	12+1	9.9	18	34	9.8	26	38	26
GN 114.2-10-20	10	20	3.3	1	12+1	9.9	18	34	9.8	26	38	27
GN 114.2-10-25	10	25	3.3	1	12+1	9.9	18	34	9.8	26	38	30
GN 114.2-10-30	10	30	3.3	1	12+1	9.9	18	34	9.8	26	38	31
GN 114.2-10-35	10	35	3.3	1	12+1	9.9	18	34	9.8	26	38	33
GN 114.2-10-40	10	40	3.3	1	12+1	9.9	18	34	9.8	26	38	35
GN 114.2-10-45	10	45	3.3	1	12+1	9.9	18	34	9.8	26	38	39
GN 114.2-10-50	10	50	3.3	1	12+1	9.9	18	34	9.8	26	38	40
GN 114.2-10-60	10	60	3.3	1	12+1	9.9	18	34	9.8	26	38	46
GN 114.2-10-70	10	70	3.3	1	12+1	9.9	18	34	9.8	26	38	50
GN 114.2-10-80	10	80	3.3	1	12+1	9.9	18	34	9.8	26	38	55
GN 114.2-10-90	10	90	3.3	1	12+1	9.9	18	34	9.8	26	38	61
GN 114.2-10-100	10	100	3.3	1	12+1	9.9	18	34	9.8	26	38	65
GN 114.2-10-110	10	110	3.3	1	12+1	9.9	18	34	9.8	26	38	70
GN 114.2-10-120	10	120	3.3	1	12+1	9.9	18	34	9.8	26	38	74
GN 114.2-12-20	12	20	3.8	1	14+1	11.9	18	34	11.3	26	61	36
GN 114.2-12-25	12	25	3.8	1	14+1	11.9	18	34	11.3	26	61	39
GN 114.2-12-30	12	30	3.8	1	14+1	11.9	18	34	11.3	26	61	43
GN 114.2-12-35	12	35	3.8	1	14+1	11.9	18	34	11.3	26	61	45
GN 114.2-12-40	12	40	3.8	1	14+1	11.9	18	34	11.3	26	61	50
GN 114.2-12-45	12	45	3.8	1	14+1	11.9	18	34	11.3	26	61	53
GN 114.2-12-50	12	50	3.8	1	14+1	11.9	18	34	11.3	26	61	60
GN 114.2-12-60	12	60	3.8	1	14+1	11.9	18	34	11.3	26	61	63
GN 114.2-12-70	12	70	3.8	1	14+1	11.9	18	34	11.3	26	61	72
GN 114.2-12-80	12	80	3.8	1	14+1	11.9	18	34	11.3	26	61	77



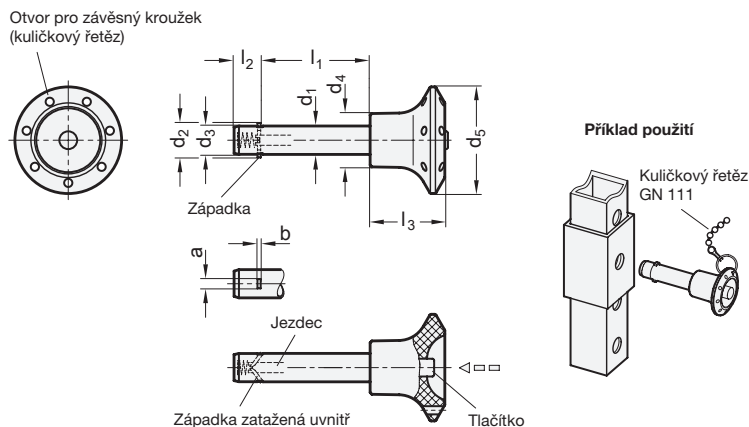

GN 114.2

Označení	d1 -0.1	l1 +0.4	a	b	d2	d3	d4	d5	l2	l3	Zatížení [kN] ≈ (Namáhání ve stříhu) viz. informace	⚖
GN 114.2-12-90	12	90	3.8	1	14 +1	11.9	18	34	11.3	26	61	87
GN 114.2-12-100	12	100	3.8	1	14 +1	11.9	18	34	11.3	26	61	94
GN 114.2-12-110	12	110	3.8	1	14 +1	11.9	18	34	11.3	26	61	108
GN 114.2-12-120	12	120	3.8	1	14 +1	11.9	18	34	11.3	26	61	110
GN 114.2-16-30	16	30	3.8	1.2	19 +1	15.9	22	40	14.2	32	113	79
GN 114.2-16-35	16	35	4.8	1.2	19 +1	15.9	22	40	14.2	32	113	85
GN 114.2-16-40	16	40	4.8	1.2	19 +1	15.9	22	40	14.2	32	113	92
GN 114.2-16-45	16	45	4.8	1.2	19 +1	15.9	22	40	14.2	32	113	99
GN 114.2-16-50	16	50	4.8	1.2	19 +1	15.9	22	40	14.2	32	113	107
GN 114.2-16-60	16	60	4.8	1.2	19 +1	15.9	22	40	14.2	32	113	119
GN 114.2-16-70	16	70	4.8	1.2	19 +1	15.9	22	40	14.2	32	113	133
GN 114.2-16-80	16	80	4.8	1.2	19 +1	15.9	22	40	14.2	32	113	146
GN 114.2-16-90	16	90	4.8	1.2	19 +1	15.9	22	40	14.2	32	113	161
GN 114.2-16-100	16	100	4.8	1.2	19 +1	15.9	22	40	14.2	32	113	174
GN 114.2-16-110	16	110	4.8	1.2	19 +1	15.9	22	40	14.2	32	113	187
GN 114.2-16-120	16	120	4.8	1.2	19 +1	15.9	22	40	14.2	32	113	200
GN 114.2-16-130	16	130	4.8	1.2	19 +1	15.9	22	40	14.2	32	113	215
GN 114.2-16-140	16	140	4.8	1.2	19 +1	15.9	22	40	14.2	32	113	230
GN 114.2-16-150	16	150	4.8	1.2	19 +1	15.9	22	40	14.2	32	113	244
GN 114.2-20-30	20	30	4.8	1.2	23 +1	19.8	25	40	14.8	33	187	118
GN 114.2-20-35	20	35	4.8	1.2	23 +1	19.8	25	40	14.8	33	187	129
GN 114.2-20-40	20	40	4.8	1.2	23 +1	19.8	25	40	14.8	33	187	139
GN 114.2-20-45	20	45	4.8	1.2	23 +1	19.8	25	40	14.8	33	187	151
GN 114.2-20-50	20	50	4.8	1.2	23 +1	19.8	25	40	14.8	33	187	162
GN 114.2-20-60	20	60	4.8	1.2	23 +1	19.8	25	40	14.8	33	187	184
GN 114.2-20-70	20	70	4.8	1.2	23 +1	19.8	25	40	14.8	33	187	207
GN 114.2-20-80	20	80	4.8	1.2	23 +1	19.8	25	40	14.8	33	187	229
GN 114.2-20-90	20	90	4.8	1.2	23 +1	19.8	25	40	14.8	33	187	258
GN 114.2-20-100	20	100	4.8	1.2	23 +1	19.8	25	40	14.8	33	187	275
GN 114.2-20-110	20	110	4.8	1.2	23 +1	19.8	25	40	14.8	33	187	300
GN 114.2-20-120	20	120	4.8	1.2	23 +1	19.8	25	40	14.8	33	187	324
GN 114.2-20-130	20	130	4.8	1.2	23 +1	19.8	25	40	14.8	33	187	342
GN 114.2-20-140	20	140	4.8	1.2	23 +1	19.8	25	40	14.8	33	187	368
GN 114.2-20-150	20	150	4.8	1.2	23 +1	19.8	25	40	14.8	33	187	390