

Panty

Zinková slitina / Nerezová ocel / Hliník

SPECIFIKACE

Typy

- Typ **A**: 2x2 otvory pro zapuštěné šrouby
- Typ **C**: 2x2 závitové kolíky

Provedení ze zinkové slitiny

Zinková slitina **ZD**

práškově lakováno

- barva černá RAL 9005, povrch s texturou **SW**
- barva stříbrná RAL 9006, povrch s texturou **SR**
- pochromovaná **CR**

Čep, nerezová ocel AISI 303

Závitový čep (Typ C), nerezová ocel AISI 316

Provedení z nerezové oceli

- AISI CF-8 **NI**
- Německá materiálová norma č. 1.4408 **A4**
- matně pískovaná **GS**

Čep, nerezová ocel AISI 316Ti

Závitové čepy (Typ C), nerezová ocel AISI 316 pro ZD a AL a nerezová ocel AISI CF-8, odlitý "v jednom kusu"

Provedení z hliníku

Hliník **AL**

eloxovaný hliník, barva přírodní **EL**

Čep, nerezová ocel AISI 316Ti

Závitový čep (Typ C), nerezová ocel AISI 316



INFORMACE

Panty GN 237 se vyznačují kompaktním a stabilním designem. Různé možnosti volby materiálů a povrchů, spolu v kombinaci se dvěma typy montáže, umožňují velmi specifické aplikace.

TECHNICKÉ INFORMACE

- Vlastnosti nerezové oceli (viz. strana A26)
- Informace o pracovním zatížení pantů (viz. strana A40)
- Seznam typů pantů (viz. strana 1362)

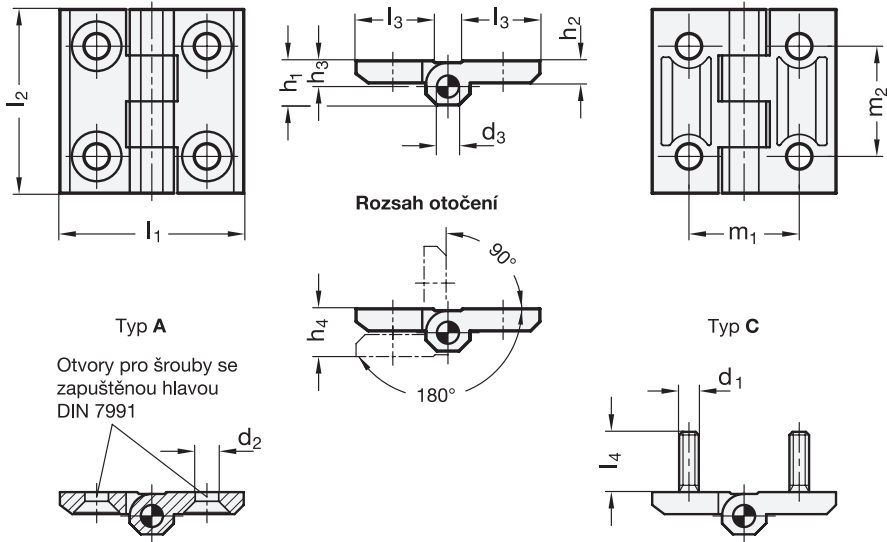

GN 237-ZD

Označení	l1	l2	d1	d2	d3	h1	h2	h3	h4 +0.5	l3	l4	m1	m2	⚖
GN 237-ZD-30-30-A-SW	30	30	-	4.3	3	7.5	4	4.5	8.5	10.7	-	18	18	19
GN 237-ZD-30-30-A-SR	30	30	-	4.3	3	7.5	4	4.5	8.5	10.7	-	18	18	19
GN 237-ZD-30-30-A-CR	30	30	-	4.3	3	7.5	4	4.5	8.5	10.7	-	18	18	19
GN 237-ZD-40-40-A-SW	40	40	-	5.3	4	9	5	5.5	11	14	-	25	25	42
GN 237-ZD-40-40-A-SR	40	40	-	5.3	4	9	5	5.5	11	14	-	25	25	45
GN 237-ZD-40-40-A-CR	40	40	-	5.3	4	9	5	5.5	11	14	-	25	25	50
GN 237-ZD-40-40-C-SW	40	40	M 5	-	4	9	5	5.5	11	14	12	25	25	59
GN 237-ZD-40-40-C-SR	40	40	M 5	-	4	9	5	5.5	11	14	12	25	25	59
GN 237-ZD-40-40-C-CR	40	40	M 5	-	4	9	5	5.5	11	14	12	25	25	69
GN 237-ZD-50-50-A-SW	50	50	-	6.4	6	11.5	6	6.5	13	18.5	-	30	30	87
GN 237-ZD-50-50-A-SR	50	50	-	6.4	6	11.5	6	6.5	13	18.5	-	30	30	89
GN 237-ZD-50-50-A-CR	50	50	-	6.4	6	11.5	6	6.5	13	18.5	-	30	30	87
GN 237-ZD-50-50-C-SW	50	50	M 6	-	6	11.5	6	6.5	13	18.5	12	30	30	102
GN 237-ZD-50-50-C-SR	50	50	M 6	-	6	11.5	6	6.5	13	18.5	12	30	30	103
GN 237-ZD-50-50-C-CR	50	50	M 6	-	6	11.5	6	6.5	13	18.5	12	30	30	102
GN 237-ZD-60-60-A-SW	60	60	-	8.3	8	15	8	8.5	17	21.5	-	36	36	160
GN 237-ZD-60-60-A-SR	60	60	-	8.3	8	15	8	8.5	17	21.5	-	36	36	160
GN 237-ZD-60-60-A-CR	60	60	-	8.3	8	15	8	8.5	17	21.5	-	36	36	164
GN 237-ZD-60-60-C-SW	60	60	M 8	-	8	15	8	8.5	17	21.5	14	36	36	200
GN 237-ZD-60-60-C-SR	60	60	M 8	-	8	15	8	8.5	17	21.5	14	36	36	190
GN 237-ZD-60-60-C-CR	60	60	M 8	-	8	15	8	8.5	17	21.5	14	36	36	194

GN 237-AL

Označení	l1	l2	d2	d3	h1	h2	h3	h4 +0.5	l3	m1	m2	⚖
GN 237-AL-30-30-A-EL	30	30	4.3	3	7.5	4	4.5	8.5	10.7	18	18	11
GN 237-AL-40-40-A-EL	40	40	5.3	4	9	5	5.5	11	14	25	25	24
GN 237-AL-50-50-A-EL	50	50	6.4	6	11.5	6	6.5	13	18.5	30	30	48
GN 237-AL-60-60-A-EL	60	60	8.3	8	15	8	8.5	17	21.5	36	36	90

GN 237-A4

STAINLESS STEEL

Označení	l1	l2	d2	d3	h1	h2	h3	h4 +0.5	l3	m1	m2	⚖
GN 237-A4-30-30-A-GS	30	30	4.3	3	7.5	4	4.5	8.5	10.7	18	18	23
GN 237-A4-40-40-A-GS	40	40	5.3	4	9	5	5.5	11	16	25	25	57
GN 237-A4-50-50-A-GS	50	50	6.4	6	11.5	6	6.5	13	21	30	30	110
GN 237-A4-60-60-A-GS	60	60	8.3	8	15	8	8.5	17	26	36	36	200

GN 237-NI

STAINLESS STEEL

Označení	l1	l2	d1	d2	d3	h1	h2	h3	h4 +0.5	l3	l4	m1	m2	⚖
GN 237-NI-30-30-A-GS	30	30	-	4.3	3	7.5	4	4.5	8.5	10.7	-	18	18	25
GN 237-NI-40-40-A-GS	40	40	-	5.3	4	9	5	5.5	11	16	-	25	25	57
GN 237-NI-40-40-C-GS	40	40	M 5	-	4	9	5	5.5	11	16	11	25	25	69
GN 237-NI-50-50-A-GS	50	50	-	6.4	6	11.5	6	6.5	13	21	-	30	30	100
GN 237-NI-50-50-C-GS	50	50	M 6	-	6	11.5	6	6.5	13	21	13	30	30	128
GN 237-NI-60-60-A-GS	60	60	-	8.3	8	15	8	8.5	17	26	-	36	36	180
GN 237-NI-60-60-C-GS	60	60	M 8	-	8	15	8	8.5	17	26	17	36	36	200

