

Nastavitelné kluzné jednotky

SPECIFIKACE

Typy

- Typ **D**: s regulačním kolečkem
- Typ **H**: s ručním kolem (velikost 50 a větší)
- Typ **DN**: s regulačním kolečkem a digitálním ukazatelem polohy DD51 (velikost 50 a větší) (viz. strana)
- Typ **DR**: s regulačním kolečkem a digitálním ukazatelem polohy DD51 (velikost 50 a větší) (viz. strana)
- Typ **HN**: s ručním kolem a digitálním ukazatelem polohy DD51 (velikost 50 a větší) (viz. strana)
- Typ **HR**: s ručním kolem a digitálním ukazatelem polohy DD51 (velikost 50 a větší) (viz. strana)
- Typ **S**: bez pohybového šroubu a ovládacího prvku (tj. připraveno k montáži pneumatického válce pro ovládání)

Označení č.

- Č. **1**: bez regulovatelné páky
- Č. **2**: s regulovatelnou pákou

Kluzné desky / Koncové dorazy

Lisovaný hliník

eloxovaný tažený polotovar, barva přírodní.

Vodící hřídele

Nerezová ocel

Pohon

- Pohybový šroub / Kuličkové ložisko
- Nerezová ocel
- Vodící matice
- Plast

Upevňovací šrouby

Nerezová ocel

Regulační kolečko / Kroužek se stupnicí

Hliník, eloxovaný černě



INFORMACE

Nastavitelné kluzné jednotky GN 900 mohou být kombinovány s řadou přídavných zařízení pro různé osové konfigurace.

Upínací lišty a spojovací moduly (GN 900.1, GN 900.2, GN 900.3) mohou být velmi rychle a jednoduše upevněny k nastavitelným kluzným jednotkám.

K přesnému nastavení slouží kruhová stupnice s přesností nastavení 0,05 mm nebo digitální ukazatel polohy s přesností nastavení 0,02 mm.

Tyto nastavitelné kluzné jednotky (Typ D, s regulačním kolečkem) jsou navíc korozivzdorné.

TECHNICKÉ INFORMACE

- Ruční kola plná VDN.FP (viz strana 162)
- Ukazatele polohy BSA-N51 (see page)

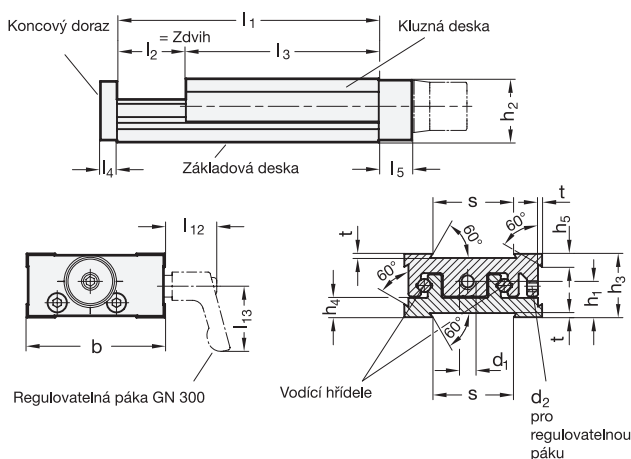

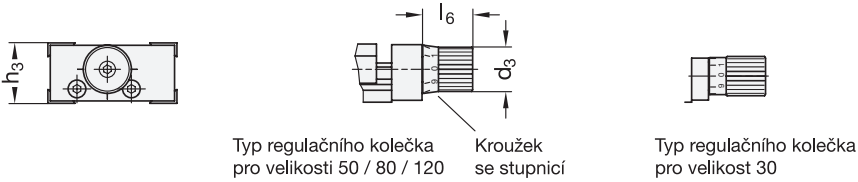

Typ regulačního kolečka pro velikosti 50 / 80 / 120

Kroužek se stupnicí

Typ regulačního kolečka pro velikost 70

*Doplňte označení nastavitelné kluzné jednotky (1 nebo 2)

- | | |
|------------------------|------------------------|
| 1 | 2 |
| bez regulovatelné páky | s regulovatelnou pákou |

GN 900-D

Označení	b	l1 - l2	d1	d2	d3	d4	d5	h1	h2	h3	h4	h5	h6	h7	h8	l3	l4	l5	l6	l7	l8	l9	l10	l11	l12	l13	s	t	Δ
GN 900-30-50-5-D-*	30	50-5	M4 x 0,5	M3	14	-	-	9.3	16	17	4	3	33	-	-	45	4	6	20	-	-	-	-	-	28	22	16	1	77
GN 900-30-55-10-D-*	30	55-10	M4 x 0,5	M3	14	-	-	9.3	16	17	4	3	33	-	-	45	4	6	20	-	-	-	-	-	28	22	16	1	80
GN 900-30-60-15-D-*	30	60-15	M4 x 0,5	M3	14	-	-	9.3	16	17	4	3	33	-	-	45	4	6	20	-	-	-	-	-	28	22	16	1	85
GN 900-30-65-20-D-*	30	65-20	M4 x 0,5	M3	14	-	-	9.3	16	17	4	3	33	-	-	45	4	6	20	-	-	-	-	-	28	22	16	1	97
GN 900-50-95-25-D-*	50	95-25	M6 x 1	M4	17	50	22	13	22.5	23	7	4.5	47	29	18	70	6	12	20	22	52	24	33	57	36	30	30	1.5	293
GN 900-50-120-50-D-*	50	120-50	M6 x 1	M4	17	50	22	13	22.5	23	7	4.5	47	29	18	70	6	12	20	22	52	24	33	57	36	30	30	1.5	340
GN 900-50-145-75-D-*	50	145-75	M6 x 1	M4	17	50	22	13	22.5	23	7	4.5	47	29	18	70	6	12	20	22	52	24	33	57	36	30	30	1.5	366
GN 900-50-170-100-D-*	50	170-100	M6 x 1	M4	17	50	22	13	22.5	23	7	4.5	47	29	18	70	6	12	20	22	52	24	33	57	36	30	30	1.5	400
GN 900-80-145-25-D-*	80	145-25	M8 x 1	M5	22	80	22	20.5	35.5	36	10	10	51	37	10	120	8	16	24	31	55	27	33	66	25	30	50	2	1060
GN 900-80-170-50-D-*	80	170-50	M8 x 1	M5	22	80	22	20.5	35.5	36	10	10	51	37	10	120	8	16	24	31	55	27	33	66	25	30	50	2	1100
GN 900-80-195-75-D-*	80	195-75	M8 x 1	M5	22	80	22	20.5	35.5	36	10	10	51	37	10	120	8	16	24	31	55	27	33	66	25	30	50	2	1220
GN 900-80-220-100-D-*	80	220-100	M8 x 1	M5	22	80	22	20.5	35.5	36	10	10	51	37	10	120	8	16	24	31	55	27	33	66	25	30	50	2	1301
GN 900-120-185-25-D-*	120	185-25	M10 x 1	M5	34	100	34	26.3	45	46	13.8	10	57	45	5	160	10	18	34	46	69	41	33	81	25	30	80	2	2768
GN 900-120-210-50-D-*	120	210-50	M10 x 1	M5	34	100	34	26.3	45	46	13.8	10	57	45	5	160	10	18	34	46	69	41	33	81	25	30	80	2	2950
GN 900-120-235-75-D-*	120	235-75	M10 x 1	M5	34	100	34	26.3	45	46	13.8	10	57	45	5	160	10	18	34	46	69	41	33	81	25	30	80	2	3118
GN 900-120-260-100-D-*	120	260-100	M10 x 1	M5	34	100	34	26.3	45	46	13.8	10	57	45	5	160	10	18	34	46	69	41	33	81	25	30	80	2	3288

Váha pro provedení číslo 1

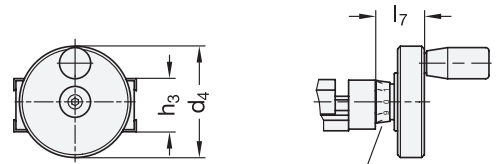

Kroužek se stupnicí

*Doplňte označení nastavitelné kluzné jednotky (1 nebo 2)

- | | |
|------------------------|------------------------|
| 1 | 2 |
| bez regulovatelné páky | s regulovatelnou pákou |

GN 900-H

Označení	b	l1 - l2	d1	d2	d3	d4	d5	h1	h2	h3	h4	h5	h6	h7	h8	l3	l4	l5	l6	l7	l8	l9	l10	l11	l12	l13	s	t	Δ
GN 900-50-95-25-H-*	50	95-25	M6 x 1	M4	17	50	22	13	22.5	23	7	4.5	47	29	18	70	6	12	20	22	52	24	33	57	36	30	30	1.5	355
GN 900-50-120-50-H-*	50	120-50	M6 x 1	M4	17	50	22	13	22.5	23	7	4.5	47	29	18	70	6	12	20	22	52	24	33	57	36	30	30	1.5	380
GN 900-50-145-75-H-*	50	145-75	M6 x 1	M4	17	50	22	13	22.5	23	7	4.5	47	29	18	70	6	12	20	22	52	24	33	57	36	30	30	1.5	421
GN 900-50-170-100-H-*	50	170-100	M6 x 1	M4	17	50	22	13	22.5	23	7	4.5	47	29	18	70	6	12	20	22	52	24	33	57	36	30	30	1.5	455
GN 900-80-145-25-H-*	80	145-25	M8 x 1	M5	22	80	22	20.5	35.5	36	10	10	51	37	10	120	8	16	24	31	55	27	33	66	25	30	50	2	1200
GN 900-80-170-50-H-*	80	170-50	M8 x 1	M5	22	80	22	20.5	35.5	36	10	10	51	37	10	120	8	16	24	31	55	27	33	66	25	30	50	2	1260
GN 900-80-195-75-H-*	80	195-75	M8 x 1	M5	22	80	22	20.5	35.5	36	10	10	51	37	10	120	8	16	24	31	55	27	33	66	25	30	50	2	1380
GN 900-80-220-100-H-*	80	220-100	M8 x 1	M5	22	80	22	20.5	35.5	36	10	10	51	37	10	120	8	16	24	31	55	27	33	66	25	30	50	2	1444
GN 900-120-185-25-H-*	120	185-25	M10 x 1	M5	34	100	34	26.3	45	46	13.8	10	57	45	5	160	10	18	34	46	69	41	33	81	25	30	80	2	2983
GN 900-120-210-50-H-*	120	210-50	M10 x 1	M5	34	100	34	26.3	45	46	13.8	10	57	45	5	160	10	18	34	46	69	41	33	81	25	30	80	2	3143
GN 900-120-235-75-H-*	120	235-75	M10 x 1	M5	34	100	34	26.3	45	46	13.8	10	57	45	5	160	10	18	34	46	69	41	33	81	25	30	80	2	3334
GN 900-120-260-100-H-*	120	260-100	M10 x 1	M5	34	100	34	26.3	45	46	13.8	10	57	45	5	160	10	18	34	46	69	41	33	81	25	30	80	2	3503

Váha pro provedení číslo 1

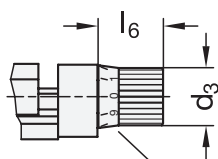
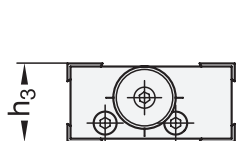

Typ regulačního kolečka
pro velikosti 50 / 80 / 120

Kroužek
se stupnicí

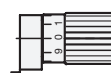

Typ regulačního kolečka
pro velikost 30

*Doplňte označení nastavitelné kluzné jednotky (1 nebo 2)

- 1 bez regulovatelné páky
2 s regulovatelnou pákou

GN 900-DN/DR

Označení	b	l1 - l2	d1	d2	d3	d4	d5	h1	h2	h3	h4	h5	h6	h7	h8	l3	l4	l5	l6	l7	l8	l9	l10	l11	l12	l13	s	t	
GN 900-50-95-25-DN-*	50	95-25	M6 x 1	M4	17	50	22	13	22.5	23	7	4.5	4.7	29	18	70	6	12	20	22	52	24	33	57	36	30	30	1.5	370
GN 900-50-120-50-DN-*	50	120-50	M6 x 1	M4	17	50	22	13	22.5	23	7	4.5	4.7	29	18	70	6	12	20	22	52	24	33	57	36	30	30	1.5	426
GN 900-50-145-75-DN-*	50	145-75	M6 x 1	M4	17	50	22	13	22.5	23	7	4.5	4.7	29	18	70	6	12	20	22	52	24	33	57	36	30	30	1.5	486
GN 900-50-170-100-DN-*	50	170-100	M6 x 1	M4	17	50	22	13	22.5	23	7	4.5	4.7	29	18	70	6	12	20	22	52	24	33	57	36	30	30	1.5	520
GN 900-80-145-25-DN-*	80	145-25	M8 x 1	M5	22	80	22	20.5	35.5	36	10	10	51	37	10	120	8	16	24	31	55	27	33	66	25	30	50	2	1200
GN 900-80-170-50-DN-*	80	170-50	M8 x 1	M5	22	80	22	20.5	35.5	36	10	10	51	37	10	120	8	16	24	31	55	27	33	66	25	30	50	2	1250
GN 900-80-195-75-DN-*	80	195-75	M8 x 1	M5	22	80	22	20.5	35.5	36	10	10	51	37	10	120	8	16	24	31	55	27	33	66	25	30	50	2	1340
GN 900-80-220-100-DN-*	80	220-100	M8 x 1	M5	22	80	22	20.5	35.5	36	10	10	51	37	10	120	8	16	24	31	55	27	33	66	25	30	50	2	1400
GN 900-120-185-25-DN-*	120	185-25	M10 x 1	M5	34	100	34	26.3	45	46	13.8	10	57	45	5	160	10	18	34	46	69	41	33	81	25	30	80	2	2922
GN 900-120-210-50-DN-*	120	210-50	M10 x 1	M5	34	100	34	26.3	45	46	13.8	10	57	45	5	160	10	18	34	46	69	41	33	81	25	30	80	2	3121
GN 900-120-235-75-DN-*	120	235-75	M10 x 1	M5	34	100	34	26.3	45	46	13.8	10	57	45	5	160	10	18	34	46	69	41	33	81	25	30	80	2	3413
GN 900-120-260-100-DN-*	120	260-100	M10 x 1	M5	34	100	34	26.3	45	46	13.8	10	57	45	5	160	10	18	34	46	69	41	33	81	25	30	80	2	3463
GN 900-50-95-25-DR-*	50	95-25	M6 x 1	M4	17	50	22	13	22.5	23	7	4.5	4.7	29	18	70	6	12	20	22	52	24	33	57	36	30	30	1.5	420
GN 900-50-120-50-DR-*	50	120-50	M6 x 1	M4	17	50	22	13	22.5	23	7	4.5	4.7	29	18	70	6	12	20	22	52	24	33	57	36	30	30	1.5	465
GN 900-50-145-75-DR-*	50	145-75	M6 x 1	M4	17	50	22	13	22.5	23	7	4.5	4.7	29	18	70	6	12	20	22	52	24	33	57	36	30	30	1.5	493
GN 900-50-170-100-DR-*	50	170-100	M6 x 1	M4	17	50	22	13	22.5	23	7	4.5	4.7	29	18	70	6	12	20	22	52	24	33	57	36	30	30	1.5	562
GN 900-80-145-25-DR-*	80	145-25	M8 x 1	M5	22	80	22	20.5	35.5	36	10	10	51	37	10	120	8	16	24	31	55	27	33	66	25	30	50	2	1180
GN 900-80-170-50-DR-*	80	170-50	M8 x 1	M5	22	80	22	20.5	35.5	36	10	10	51	37	10	120	8	16	24	31	55	27	33	66	25	30	50	2	1263
GN 900-80-195-75-DR-*	80	195-75	M8 x 1	M5	22	80	22	20.5	35.5	36	10	10	51	37	10	120	8	16	24	31	55	27	33	66	25	30	50	2	1330
GN 900-80-220-100-DR-*	80	220-100	M8 x 1	M5	22	80	22	20.5	35.5	36	10	10	51	37	10	120	8	16	24	31	55	27	33	66	25	30	50	2	1415
GN 900-120-185-25-DR-*	120	185-25	M10 x 1	M5	34	100	34	26.3	45	46	13.8	10	57	45	5	160	10	18	34	46	69	41	33	81	25	30	80	2	2900
GN 900-120-210-50-DR-*	120	210-50	M10 x 1	M5	34	100	34	26.3	45	46	13.8	10	57	45	5	160	10	18	34	46	69	41	33	81	25	30	80	2	3074
GN 900-120-235-75-DR-*	120	235-75	M10 x 1	M5	34	100	34	26.3	45	46	13.8	10	57	45	5	160	10	18	34	46	69	41	33	81	25	30	80	2	3244
GN 900-120-260-100-DR-*	120	260-100	M10 x 1	M5	34	100	34	26.3	45	46	13.8	10	57	45	5	160	10	18	34	46	69	41	33	81	25	30	80	2	3424

Váha pro provedení číslo 1



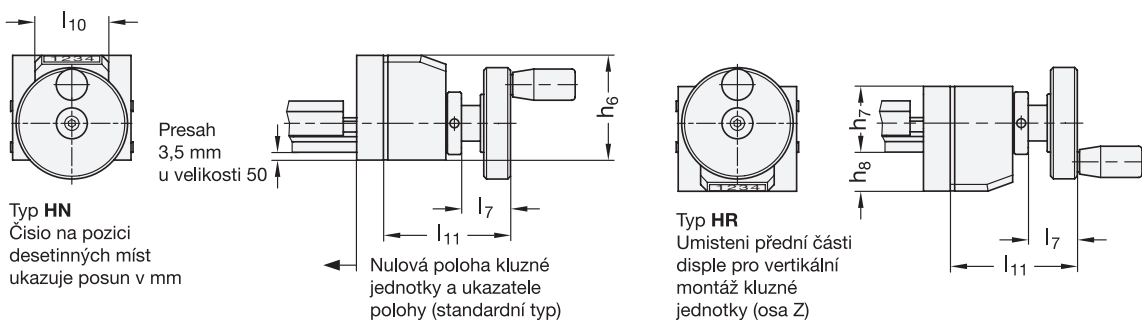

*Doplňte označení nastavitelné kluzné jednotky (1 nebo 2)

- 1 bez regulovatelné páky
- 2 s regulovatelnou pákou

GN 900-HN/HR

Označení	b	l1 - l2	d1	d2	d3	d4	d5	h1	h2	h3	h4	h5	h6	h7	h8	l3	l4	l5	l6	l7	l8	l9	l10	l11	l12	l13	s	t	Δ
GN 900-50-95-25-HN-*	50	95-25	M6 x1	M4	17	50	22	13	22.5	23	7	4.5	47	29	18	70	6	12	20	22	52	24	33	57	36	30	30	1.5	480
GN 900-50-120-50-HN-*	50	120-50	M6 x1	M4	17	50	22	13	22.5	23	7	4.5	47	29	18	70	6	12	20	22	52	24	33	57	36	30	30	1.5	500
GN 900-50-145-75-HN-*	50	145-75	M6 x1	M4	17	50	22	13	22.5	23	7	4.5	47	29	18	70	6	12	20	22	52	24	33	57	36	30	30	1.5	540
GN 900-50-170-100-HN-*	50	170-100	M6 x1	M4	17	50	22	13	22.5	23	7	4.5	47	29	18	70	6	12	20	22	52	24	33	57	36	30	30	1.5	580
GN 900-80-145-25-HN-*	80	145-25	M8 x1	M5	22	80	22	20.5	35.5	36	10	10	51	37	10	120	8	16	24	31	55	27	33	66	25	30	50	2	1344
GN 900-80-170-50-HN-*	80	170-50	M8 x1	M5	22	80	22	20.5	35.5	36	10	10	51	37	10	120	8	16	24	31	55	27	33	66	25	30	50	2	1350
GN 900-80-195-75-HN-*	80	195-75	M8 x1	M5	22	80	22	20.5	35.5	36	10	10	51	37	10	120	8	16	24	31	55	27	33	66	25	30	50	2	1489
GN 900-80-220-100-HN-*	80	220-100	M8 x1	M5	22	80	22	20.5	35.5	36	10	10	51	37	10	120	8	16	24	31	55	27	33	66	25	30	50	2	1560
GN 900-120-185-25-HN-*	120	185-25	M10 x1	M5	34	100	34	26.3	45	46	13.8	10	57	45	5	160	10	18	34	46	69	41	33	81	25	30	80	2	3135
GN 900-120-210-50-HN-*	120	210-50	M10 x1	M5	34	100	34	26.3	45	46	13.8	10	57	45	5	160	10	18	34	46	69	41	33	81	25	30	80	2	3335
GN 900-120-235-75-HN-*	120	235-75	M10 x1	M5	34	100	34	26.3	45	46	13.8	10	57	45	5	160	10	18	34	46	69	41	33	81	25	30	80	2	3627
GN 900-120-260-100-HN-*	120	260-100	M10 x1	M5	34	100	34	26.3	45	46	13.8	10	57	45	5	160	10	18	34	46	69	41	33	81	25	30	80	2	3677
GN 900-50-95-25-HR-*	50	95-25	M6 x1	M4	17	50	22	13	22.5	23	7	4.5	47	29	18	70	6	12	20	22	52	24	33	57	36	30	30	1.5	480
GN 900-50-120-50-HR-*	50	120-50	M6 x1	M4	17	50	22	13	22.5	23	7	4.5	47	29	18	70	6	12	20	22	52	24	33	57	36	30	30	1.5	540
GN 900-50-145-75-HR-*	50	145-75	M6 x1	M4	17	50	22	13	22.5	23	7	4.5	47	29	18	70	6	12	20	22	52	24	33	57	36	30	30	1.5	550
GN 900-50-170-100-HR-*	50	170-100	M6 x1	M4	17	50	22	13	22.5	23	7	4.5	47	29	18	70	6	12	20	22	52	24	33	57	36	30	30	1.5	800
GN 900-80-145-25-HR-*	80	145-25	M8 x1	M5	22	80	22	20.5	35.5	36	10	10	51	37	10	120	8	16	24	31	55	27	33	66	25	30	50	2	1320
GN 900-80-170-50-HR-*	80	170-50	M8 x1	M5	22	80	22	20.5	35.5	36	10	10	51	37	10	120	8	16	24	31	55	27	33	66	25	30	50	2	1406
GN 900-80-195-75-HR-*	80	195-75	M8 x1	M5	22	80	22	20.5	35.5	36	10	10	51	37	10	120	8	16	24	31	55	27	33	66	25	30	50	2	1282
GN 900-80-220-100-HR-*	80	220-100	M8 x1	M5	22	80	22	20.5	35.5	36	10	10	51	37	10	120	8	16	24	31	55	27	33	66	25	30	50	2	1560
GN 900-120-185-25-HR-*	120	185-25	M10 x1	M5	34	100	34	26.3	45	46	13.8	10	57	45	5	160	10	18	34	46	69	41	33	81	25	30	80	2	3122
GN 900-120-210-50-HR-*	120	210-50	M10 x1	M5	34	100	34	26.3	45	46	13.8	10	57	45	5	160	10	18	34	46	69	41	33	81	25	30	80	2	3288
GN 900-120-235-75-HR-*	120	235-75	M10 x1	M5	34	100	34	26.3	45	46	13.8	10	57	45	5	160	10	18	34	46	69	41	33	81	25	30	80	2	3457
GN 900-120-260-100-HR-*	120	260-100	M10 x1	M5	34	100	34	26.3	45	46	13.8	10	57	45	5	160	10	18	34	46	69	41	33	81	25	30	80	2	3637

Váha pro provedení číslo 1

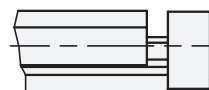
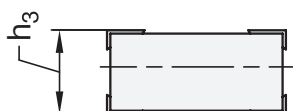

* Doplňte označení nastavitelné kluzné jednotky (1 nebo 2)

- 1 bez regulovatelné páky
2 s regulovatelnou pákou

GN 900-S

Označení	b	l1 - l2	d1	d2	d3	d4	d5	h1	h2	h3	h4	h5	h6	h7	h8	l3	l4	l5	l6	l7	l8	l9	l10	l11	l12	l13	s	t	⚖
GN 900-30-50-5-S-*	30	50-5	M4 x 0,5 M3	14	-	-	9.3	16	17	4	3	33	-	-	45	4	6	20	-	-	-	-	-	28	22	16	1	70	
GN 900-30-55-10-S-*	30	55-10	M4 x 0,5 M3	14	-	-	9.3	16	17	4	3	33	-	-	45	4	6	20	-	-	-	-	-	28	22	16	1	76	
GN 900-30-60-15-S-*	30	60-15	M4 x 0,5 M3	14	-	-	9.3	16	17	4	3	33	-	-	45	4	6	20	-	-	-	-	-	28	22	16	1	80	
GN 900-30-65-20-S-*	30	65-20	M4 x 0,5 M3	14	-	-	9.3	16	17	4	3	33	-	-	45	4	6	20	-	-	-	-	-	28	22	16	1	88	
GN 900-50-95-25-S-*	50	95-25	M6 x 1 M4	17	50	22	13	22.5	23	7	4.5	47	29	18	70	6	12	20	22	52	24	33	57	36	30	30	1.5	252	
GN 900-50-120-50-S-*	50	120-50	M6 x 1 M4	17	50	22	13	22.5	23	7	4.5	47	29	18	70	6	12	20	22	52	24	33	57	36	30	30	1.5	276	
GN 900-50-145-75-S-*	50	145-75	M6 x 1 M4	17	50	22	13	22.5	23	7	4.5	47	29	18	70	6	12	20	22	52	24	33	57	36	30	30	1.5	306	
GN 900-50-170-100-S-*	50	170-100	M6 x 1 M4	17	50	22	13	22.5	23	7	4.5	47	29	18	70	6	12	20	22	52	24	33	57	36	30	30	1.5	340	
GN 900-80-145-25-S-*	80	145-25	M8 x 1 M5	22	80	22	20.5	35.5	36	10	10	51	37	10	120	8	16	24	31	55	27	33	66	25	30	50	2	950	
GN 900-80-170-50-S-*	80	170-50	M8 x 1 M5	22	80	22	20.5	35.5	36	10	10	51	37	10	120	8	16	24	31	55	27	33	66	25	30	50	2	1000	
GN 900-80-195-75-S-*	80	195-75	M8 x 1 M5	22	80	22	20.5	35.5	36	10	10	51	37	10	120	8	16	24	31	55	27	33	66	25	30	50	2	1080	
GN 900-80-220-100-S-*	80	220-100	M8 x 1 M5	22	80	22	20.5	35.5	36	10	10	51	37	10	120	8	16	24	31	55	27	33	66	25	30	50	2	1160	
GN 900-120-185-25-S-*	120	185-25	M10 x 1 M5	34	100	34	26.3	45	46	13.8	10	57	45	5	160	10	18	34	46	69	41	33	81	25	30	80	2	2500	
GN 900-120-210-50-S-*	120	210-50	M10 x 1 M5	34	100	34	26.3	45	46	13.8	10	57	45	5	160	10	18	34	46	69	41	33	81	25	30	80	2	2700	
GN 900-120-235-75-S-*	120	235-75	M10 x 1 M5	34	100	34	26.3	45	46	13.8	10	57	45	5	160	10	18	34	46	69	41	33	81	25	30	80	2	2829	
GN 900-120-260-100-S-*	120	260-100	M10 x 1 M5	34	100	34	26.3	45	46	13.8	10	57	45	5	160	10	18	34	46	69	41	33	81	25	30	80	2	2975	

Váha pro provedení číslo 1

