

Madla prstová

Ocel

SPECIFIKACE

Ocel
 pochromovaná **CR**
 Opěrné podložky
 Zinková slitina, poniklovaná



Madla prstová z nerezí

SPECIFIKACE

Nerezová ocel AISI 304
 matně pískovaná
 Opěrné podložky
 Nerezová ocel AISI 303

TECHNICKÉ INFORMACE

- Vlastnosti nerezové oceli (viz. strana A26)

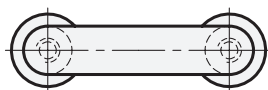
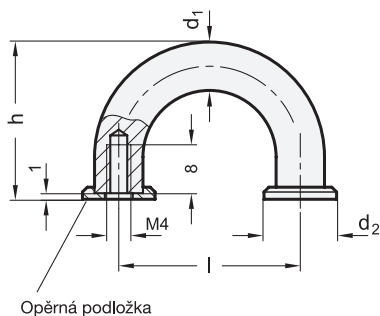

GN 224.1

Označení	d1	l ±0.25	d2	h	ΔΔ
GN 224.1-8-30-CR	8	30	12	26	23
GN 224.1-10-40-CR	10	40	15	31	40

GN 224.5

STAINLESS STEEL

Označení	d1	l ±0.25	d2	h	ΔΔ
GN 224.5-8-30	8	30	12	26	20
GN 224.5-10-40	10	40	15	31	50



4
Madla