

GN 237.3-elongated



Stainless Steel- Heavy duty hinges

horizontally elongated

SPECIFICATION

Types

- Type **A**: with bores for countersunk screws
- Type **B**: with bores for countersunk screws and centering attachments

Stainless Steel **NI**
German Material No. 1.4405

- matte shot-blasted **GS**
- plastic coated
- black, RAL 9005, textured finish **SW**

Hinge pin
Stainless Steel

- German Material No 1.4542
- tempered
- with special grease lubricated

Shim washers
Stainless Steel AISI 301

- tempered
- with special grease lubricated



INFORMATION

Horizontally elongated Stainless Steel-Heavy duty hinges GN 237.3 are designed for use under tough conditions. Attachment points with a wider spacing and more installation holes allow a more effective introduction of force into the mounting surface. The hinge pins are integral and allow the hinges to be used in environments with strong vibrations and shocks.

The selected materials allow the hinges to be used in aggressive environments. Wear is minimized by the effective friction pairing of the hinge components and lubrication.

The type B hinge has centering attachments that prevent lateral slippage under high loads and protect the mounting screws from impermissible transverse force.

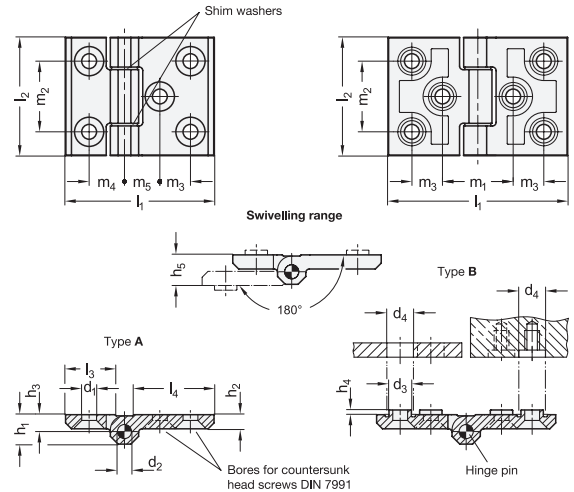

TECHNICAL INFORMATION

- Stainless Steel characteristics (see page)
- Load rating information of hinges (see page)

* Complete with colour index of the Hinges (SW or GS)

SW	GS
RAL9005	matte shot-blasted

GN 237.3-elongated

Description	l1 extended on both sides	l1 Pin	l2	d1	d2	d3	d4 +0.5	h1	h2	h3	h4	h5	l3	l4	m1	m2	m3	m4	m5	⚖
GN 237.3-NI-63-50-A-*	63	-	50	6.3	6	9.5	10	12.5	6	6.5	2	13	21	34	-	30	13	15	15	140
GN 237.3-NI-76-50-A-*	-	76	50	6.3	6	9.5	10	12.5	6	6.5	2	13	34	34	30	30	13	-	-	165
GN 237.3-NI-90-60-A-*	90	-	60	8.3	8	12.5	13	16	8	8.5	3	17	25.5	56	-	36	22.5	18	22.5	312
GN 237.3-NI-120-60-A-*	-	120	60	8.3	8	12.5	13	16	8	8.5	3	17	56	56	45	36	22.5	-	-	410
GN 237.3-NI-120-80-A-*	120	-	80	10.3	10	14.5	15	20	10	10.5	4	21	36	75	-	50	30	25	30	700
GN 237.3-NI-160-80-A-*	-	160	80	10.3	10	14.5	15	20	10	10.5	4	21	75	75	60	50	30	-	-	910
GN 237.3-NI-63-50-B-*	63	-	50	6.3	6	9.5	10	12.5	6	6.5	2	13	21	34	-	30	13	15	15	141
GN 237.3-NI-76-50-B-*	-	76	50	6.3	6	9.5	10	12.5	6	6.5	2	13	34	34	30	30	13	-	-	165
GN 237.3-NI-90-60-B-*	90	-	60	8.3	8	12.5	13	16	8	8.5	3	17	25.5	56	-	36	22.5	18	22.5	320
GN 237.3-NI-120-60-B-*	-	120	60	8.3	8	12.5	13	16	8	8.5	3	17	56	56	45	36	22.5	-	-	420
GN 237.3-NI-120-80-B-*	120	-	80	10.3	10	14.5	15	20	10	10.5	4	21	36	75	-	50	30	25	30	700
GN 237.3-NI-160-80-B-*	-	160	80	10.3	10	14.5	15	20	10	10.5	4	21	75	75	60	50	30	-	-	910

Weight type GS