

Ruční kliky

Litina

SPECIFIKACE

Typy

- Typ **F**: s pevnou rukojetí
- Typ **D**: s otočnou rukojetí

Tělo

Litina (GG)

- práškově lakováno, barva černá, povrch s texturou
- náboj obrobený

Pevné rukojeti DIN 39 (viz. strana 565)

Pozinkovaná ocel, modrý pozink

Otočné rukojeti DIN 98 (viz. strana 579)

Pozinkovaná ocel, modrý pozink



INFORMACE

Otvory v náboji d1 H7 nejsou uvedeny v oficiálním listu norem.

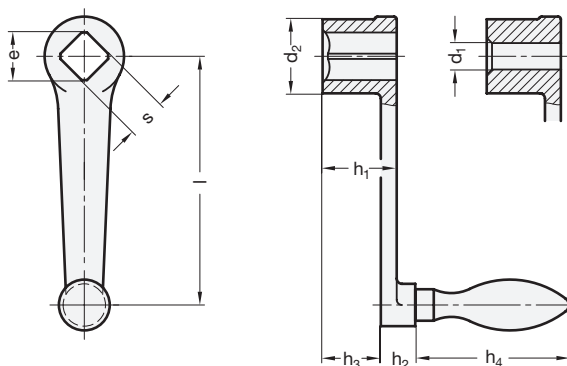

* Doplníte typ kliky (F nebo D)

F **D**
pevná rukojeť otočná rukojeť

DIN 469

Označení	l	s H11	e min.	d1 H7	d2	h1	h2	h3 ≈	h4 ≈ Typ D	h4 ≈ Typ F	Ø Páka	⚖
DIN 469-63-V10-*	63	V 10	13.1	-	20	20	11	15	54.5	50	16	110
DIN 469-80-B8-*	80	-	13.1	B 8	24	24	13	18	61	56	18	203
DIN 469-80-V10-*	80	V 10	13.1	-	24	24	13	18	61	56	18	179
DIN 469-80-V12-*	80	V 12	13.1	-	24	24	13	18	61	56	18	170
DIN 469-100-B10-*	100	-	16.1	B 10	28	28	13	21	67	64	20	288
DIN 469-100-V12-*	100	V 12	16.1	-	28	28	13	21	67	64	20	271
DIN 469-100-V14-*	100	V 14	16.1	-	28	28	13	21	67	64	20	264
DIN 469-125-B10-*	125	-	18.1	B 10	34	34	14	26	76	72	22	458
DIN 469-125-V14-*	125	V 14	18.1	-	34	34	14	26	76	72	22	434
DIN 469-125-V17-*	125	V 17	18.1	-	34	34	14	26	76	72	22	414
DIN 469-160-B14-*	160	-	22.2	B 14	38	38	14	29	83	80	25	677
DIN 469-160-V17-*	160	V 17	22.2	-	38	38	14	29	83	80	25	642
DIN 469-160-V19-*	160	V 19	22.2	-	38	38	14	29	83	80	25	604
DIN 469-200-B17-*	200	-	25.2	B 17	44	44	21	34	96.5	90	28	1021
DIN 469-200-V19-*	200	V 19	25.2	-	44	44	21	34	96.5	90	28	998
DIN 469-200-V22-*	200	V 22	25.2	-	44	44	21	34	96.5	90	28	970
DIN 469-250-B17-*	250	-	28.2	B 17	48	48	21	36	105.5	100	32	1412
DIN 469-250-V22-*	250	V 22	28.2	-	48	48	21	36	105.5	100	32	1332
DIN 469-250-V24-*	250	V 24	28.2	-	48	48	21	36	105.5	100	32	1281

Váha pro typ F

