

## Vidlicové hlavy

### SPECIFIKACE

#### Provedení z oceli

Ocel

- Pevnost v tahu třídy 5
- pozinkovaná, modrý pozink

#### Provedení z hliníku

Hliník AL

eloxovaný hliník, barva černá

#### Provedení z nerezové oceli

Nerezová ocel AISI 303 NI

bez povrchové úpravy

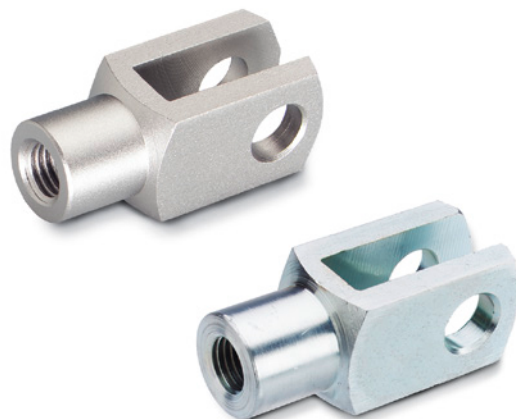

### INFORMACE

Velikost  $d_1 = 12$  je dodávána s jemným závitem M12x1,5 dle normy DIN. V praxi je však více používána velikost závitu M12x1,25. Standard dle DIN 71752 nenabízí větší velikost než  $d_1 = 20$ .

### TECHNICKÉ INFORMACE

- Základní tolerance ISO (viz. strana A21)
- Vlastnosti nerezové oceli (viz. strana A26)
- Hodnoty pevnosti matic (viz. strana A20)

### NA POPTÁVKU

- Vidlicové hlavy dle normy DIN 71752 s rozměrem  $d_1 = 25, 30, 35, 42$  a 50 (pouze provedení z oceli)
- Vidlicové hlavy dle normy DIN 71752 s rozměrem  $d_1 = 30$  a 35 (pouze provedení z nerezové oceli)

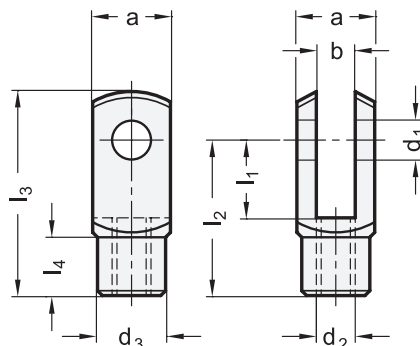

\* Doplněte označení o materiál vidlicové hlavy (AL nebo NI)

AL	NI
Hliník	Nerezová ocel

### DIN 71752

STAINLESS STEEL

Označení	$d_1$ H9/h11	$l_1$	$d_2$	$a$	$b$	$d_3$	$l_2$	$l_3$	$l_4$
DIN 71752-4-8-M4-*	4**	8	M 4	8	4	8	16	21	6
DIN 71752-4-16-M4-*	4**	16	M 4	8	4	8	24	29	6
DIN 71752-5-10-M5-*	5**	10	M 5	10	5	9	20	26	7,5
DIN 71752-5-20-M5-*	5**	20	M 5	10	5	9	30	36	7,5
DIN 71752-6-12-M6-*	6**	12	M 6	12	6	10	24	31	9
DIN 71752-6-24-M6-*	6**	24	M 6	12	6	10	36	43	9
DIN 71752-8-16-M8-*	8**	16	M 8	16	8	14	32	42	12
DIN 71752-8-32-M8-*	8**	32	M 8	16	8	14	48	58	12
DIN 71752-10-20-M10-*	10**	20	M 10	20	10	18	40	52	15
DIN 71752-10-40-M10-*	10**	40	M 10	20	10	18	60	72	15
DIN 71752-12-24-M12-*	12**	24	M 12	24	12	20	48	62	18
DIN 71752-12-48-M12-*	12**	48	M 12	24	12	20	72	86	18
DIN 71752-14-28-M14-*	14**	28	M 14	28	14	24	56	72	22,5
DIN 71752-14-56-M14-*	14**	56	M 14	28	14	24	85	101	22,5
DIN 71752-16-32-M16-*	16**	32	M 16	32	16	26	64	83	24
DIN 71752-16-64-M16-*	16**	64	M 16	32	16	26	96	115	24
DIN 71752-20-40-M20-*	20**	40	M 20	40	20	34	80	105	30

Váha pro typ AL

\*\* Hliníkové provedení není běžně skladem, vyžaduje objednávku minimálního množství

## DIN 71752-Steel

Označení	d1 H9/h11	l1	d2	a	b	d3	l2	l3	l4	⚖
DIN 71752-4-8-M4	4	8	M 4	8	4	8	16	21	6	5
DIN 71752-4-16-M4	4	16	M 4	8	4	8	24	29	6	7
DIN 71752-5-10-M5	5	10	M 5	10	5	9	20	26	7.5	9
DIN 71752-5-10-M5L	5	10	M 5L	10	5	9	20	26	7.5	9
DIN 71752-5-20-M5	5	20	M 5	10	5	9	30	36	7.5	13
DIN 71752-5-20-M5L	5	20	M 5L	10	5	9	30	36	7.5	13
DIN 71752-6-12-M6	6	12	M 6	12	6	10	24	31	9	14
DIN 71752-6-12-M6L	6	12	M 6L	12	6	10	24	31	9	11
DIN 71752-6-24-M6	6	24	M 6	12	6	10	36	43	9	21
DIN 71752-6-24-M6L	6	24	M 6L	12	6	10	36	43	9	21
DIN 71752-8-16-M8	8	16	M 8	16	8	14	32	42	12	36
DIN 71752-8-16-M8L	8	16	M 8L	16	8	14	32	42	12	36
DIN 71752-8-16-M8F	8	16	M 8F = M8x1	16	8	14	32	42	12	36
DIN 71752-8-32-M8	8	32	M 8	16	8	14	48	58	12	52
DIN 71752-8-32-M8L	8	32	M 8L	16	8	14	48	58	12	52
DIN 71752-8-32-M8F	8	32	M 8F = M8x1	16	8	14	48	58	12	52
DIN 71752-10-20-M10	10	20	M 10	20	10	18	40	52	15	72
DIN 71752-10-20-M10L	10	20	M 10L	20	10	18	40	52	15	72
DIN 71752-10-20-M10F	10	20	M 10F = M10x1.25	20	10	18	40	52	15	72
DIN 71752-10-40-M10	10	40	M 10	20	10	18	60	72	15	102
DIN 71752-10-40-M10L	10	40	M 10L	20	10	18	60	72	15	102
DIN 71752-10-40-M10F	10	40	M 10F = M10x1.25	20	10	18	60	72	15	102
DIN 71752-12-24-M12	12	24	M 12	24	12	20	48	62	18	117
DIN 71752-12-24-M12L	12	24	M 12L	24	12	20	48	62	18	117
DIN 71752-12-24-M12F	12	24	M 12F = M12x1.25	24	12	20	48	62	18	117
DIN 71752-12-48-M12	12	48	M 12	24	12	20	72	86	18	165
DIN 71752-12-48-M12L	12	48	M 12L	24	12	20	72	86	18	165
DIN 71752-12-48-M12F	12	48	M 12F = M12x1.25	24	12	20	72	86	18	165
DIN 71752-14-28-M14	14	28	M 14	28	14	24	56	72	22.5	171
DIN 71752-14-28-M14L	14	28	M 14L	28	14	24	56	72	22.5	171
DIN 71752-14-28-M14F	14	28	M 14F = M14x1.5	28	14	24	56	72	22.5	171
DIN 71752-14-56-M14	14	56	M 14	28	14	24	85	101	22.5	248
DIN 71752-14-56-M14L	14	56	M 14L	28	14	24	85	101	22.5	248
DIN 71752-14-56-M14F	14	56	M 14F = M14x1.5	28	14	24	85	101	22.5	248
DIN 71752-16-32-M16	16	32	M 16	32	16	26	64	83	24	267
DIN 71752-16-32-M16L	16	32	M 16L	32	16	26	64	83	24	267
DIN 71752-16-32-M16F	16	32	M 16F = M16x1.5	32	16	26	64	83	24	267
DIN 71752-16-64-M16	16	64	M 16	32	16	26	96	115	24	380
DIN 71752-16-64-M16L	16	64	M 16L	32	16	26	96	115	24	393
DIN 71752-16-64-M16F	16	64	M 16F = M16x1.5	32	16	26	96	115	24	393
DIN 71752-20-40-M20	20	40	M 20	40	20	34	80	105	30	520
DIN 71752-20-40-M20L	20	40	M 20L	40	20	34	80	105	30	520

